

Guide to Proper Bearing Lubrication Procedures

Contents:

- [Cleaning](#)
- [Run-In Procedures](#)
- [Grease Sampling Procedure](#)
- [Ensuring Proper Fill Quantity](#)
- [Grease Filling a Bearing](#)
- [Grease Change-Over Procedure](#)
- [Determining Bearing Free Space](#)
- [How to Use a Grease Gun](#)
- [Lubricant Storage and Shelf Life](#)

Understanding proper bearing lubrication procedures is critical to ensuring long-term, trouble-free performance. Klüber Lubrication has prepared this explanation as a general guide. If a more detailed explanation is required, please contact your nearest Klüber Lubrication representative or the manufacturer of the lubricant you are using.

Although these procedures apply specifically to grease lubricated bearings, the information contained herein may be useful in other similar applications.

Before you lubricate any bearing, it is very important to select the proper lubricant based on the specific requirements of the application. Factors such as speed, type and size of bearing, temperature (ambient and bearing) and surrounding media have to be considered carefully to select a lubricant which will provide the desired service. Klüber Lubrication representatives are carefully trained to assist in selecting the best product to use.

What are the benefits?

The main objective in using these procedures is to produce a system where the lubricant is operating at its most efficient state. This means that the lubricant is set correctly in the bearing using the proper quantity of product and that the bearing is operating at the lowest possible steady-state operating temperature. This provides the necessary situation for long life, high-speed running without excessive heat generation. Keep in mind that excessive bearing temperatures will decrease both lubricant life as well as system operating precision.

The importance of following procedures

The procedure followed in applying a lubricant can be as important as the lubricant selected. Three areas which are of particular importance in the application of a lubricant are:

- Bearing Cleaning
- Lubricant Fill Quantity
- Bearing Run-In

When do they become important?

High-speed precision machine tool spindle bearings that are grease lubricated (without the availability of relubrication) must follow these specific procedures in order to operate successfully. Those applications where the operating parameters have become critical (such as bearings and/or lubricants that are operating close to their rated speeds or applications that are lubricated-for-life) may also benefit from these procedures. Other less critical applications may also benefit from these procedures, although it is possible to operate successfully without them. The apparent benefits become clear as the bearing speed exceeds 500,000 nDm (n = bearing rpm, Dm = mean diameter of bearing in mm).

You may find from experience that some applications require more attention than others or that some applications may allow some steps to be eliminated. It is, therefore, important that you fully document and review each application procedure so that you can achieve future benefits from the information you have accumulated.

Cleaning

Part 1

The removal of any existing oils, greases and anti-corrosion coatings increases in importance as the operating life and reliability of the application becomes more and more critical. The wetting of the contact surface by the lubricating film will be enhanced by a clean contact surface. Removal of these oils, greases and coatings will also eliminate any potential incompatibilities that may exist between these products and the subject lubricant. It is always advisable to remove these materials prior to applying silicone or perfluorinated-based products.

Existing surface coatings can act as separating agents, preventing the applied grease from wetting the bearing balls and races properly. For applications that operate in the high speed range ($nDm > 800,000$ or $n/ng^* > 0.8$), or when a specialty lubricant is being used, a clean, dry surface may be critical to ensure the proper adhesion between the grease thickener matrix and the bearing surfaces.

Many bearing companies provide their products pre-coated with an oil film and/or anticorrosion coating. If this coating has both a micro-thickness and is compatible with the chosen lubricant, then a pre-cleaning may not be necessary. It is important to discuss this situation with the subject bearing and lubricant supplier.

Use of a non-residual solvent for the cleaning of bearing surfaces provides the optimum lubrication condition. Prior to selecting a suitable industrial solvent, it is important to refer to any applicable federal, state, local or global regulations regarding their restrictions or proper use.

The most efficient non-residual solvents were CFC-113 (Freon® TF) and methyl chloroform (1,1,1 Trichloroethane). However, restrictions on ozone-depleting chemicals prohibit the use of these solvent types. In this case, the best allowable non-residual solvent should be used.



The application criteria, along with the degree of contamination, will determine the extent of cleaning and whether multiple cleanings or ultrasonic cleaning is necessary.

As the cleaned parts dry, they become prone to atmospheric corrosion. If immediate lubrication is not possible, the parts should be coated with a dispersion of the intended lubricant prior to storage. Even if the bearings are immediately lubricated, the “non-lubricated” surfaces are still prone to corrosion. Therefore, it is advisable to apply a light anti-corrosion coating to these bearing surfaces after lubrication.

* n = bearing rpm, ng = speed rating of bearing using grease (rpm)

Ensuring Proper Fill Quantity

Part 2

The proper fill quantity is important to ensure that all contact surfaces are provided with a suitable lubricating film over the designed operating life. Over-lubrication can be as detrimental as under-lubrication. With over-lubrication, there is an increase in the internal friction of the component as excess lubricant is moved through the free space. This results in increased heat generation and, therefore, a shorter application operating life. With under-lubrication, a boundary lubrication condition will occur, as all contact surfaces are not supplied with the proper quantity of lubricant. This condition may lead to wear and/or lubrication starvation resulting in shorter operating life.

The correct lubricant quantity is determined by the design, operating speeds, reservoir volume and the extent of sealing or shielding found in the application. The objective of the lubricant fill quantity is to provide the contact surfaces with a consistent lubricating film thick enough to prevent metal-to-metal contact and support full fluid film lubrication.

Fill quantity becomes of particular interest when the application requires the use of grease lubricated bearings. The bearing modified speed factor ($ka \cdot nDm$ – see table below for correction factors) for the application becomes an important factor in determining the proper grease quantity.

| Bearing Types | nDm Correction Factor |
|---|-----------------------|
| <ul style="list-style-type: none"> • Deep Groove Ball • Cylindrical Roller | 1.00 |
| <ul style="list-style-type: none"> • Angular Contact Ball • Double Row Ball | 0.90 |
| <ul style="list-style-type: none"> • Needle Roller with Cage | 0.70 |
| <ul style="list-style-type: none"> • Spherical Double Row • Taper Roller | 0.60 |
| <ul style="list-style-type: none"> • Full Compliment Needle Roller | 0.40 |

When the lubricating film is setting up during run-in, excess lubricant will be expelled from the contact surface area. It is important that this excess lubricant is not restricted from leaving

the contact surface area so as not to increase the internal friction of the system. When the application is sealed or shielded (no exit path for the excess lubricant), it becomes especially important to choose the proper fill quantity.

By providing a cavity outside of the contact area greater than the static free space of the bearing, there is enough of an area available for the excess lubricant. This cavity will also provide a lubricant reservoir that may continually feed the lubrication point, through capillary action, during operation. This cavity must be large enough to be able to contain the total volume of excess lubricant, but small enough to ensure the proper capillary action. The availability of a proper grease reservoir can aid in sealing and extend the overall lubricant life.

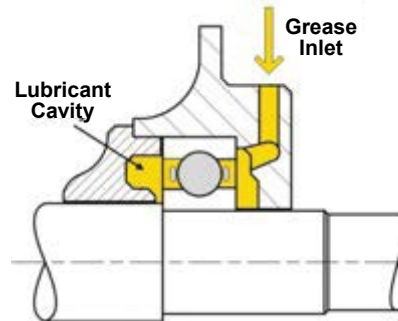

Most bearing and grease manufacturers recommend the following rules of thumb for bearing fill quantity. The area marked in yellow indicates the grease fill as a function of the speed factor.

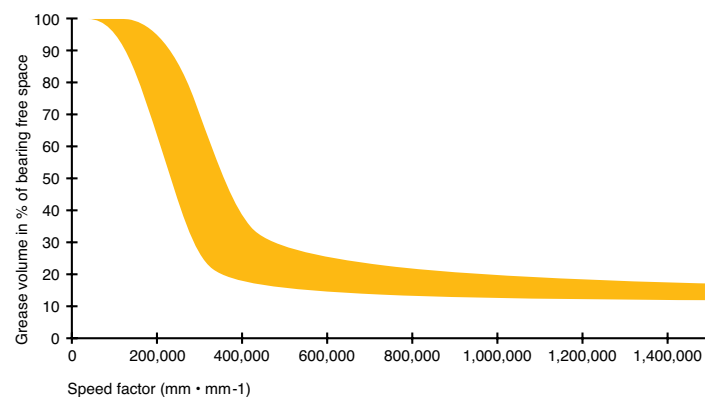

Note: Special attention must be given to relubrication quantities so that an over-lubrication condition is avoided. Typical relubrication amounts are 1/3 to 1/2 of the original fill quantity.

Determining Bearing Free Space

Part 3

The proper fill quantity of a grease lubricated bearing is often specified as a percentage of the bearing's free space. It is, therefore, important that the bearing's free space is accurately determined. Some of the available methods for determining a bearing's free space are described below. These methods are listed according to both accuracy of results as well as simplicity, with the simplest and most accurate method presented first.

Published Engineering Data

Many bearing manufacturers have already determined the free space for a number of their catalog bearings. Because each manufacturer maintains design information on his bearings, a simple phone call to the engineering department of the bearing manufacturer will result in the most accurate value for a specific bearing's free space. Unfortunately, due to the large number of catalog bearings available, coupled with the relatively minor importance of this information, some bearing manufacturers do not have ready access to every bearing's free space.

Published Reference Charts

Many major bearing manufacturers have developed generalized bearing free space reference charts. These charts help the user calculate a specific bearing's free space based on the bearing's design configuration and inner diameter. Compiling this information for all bearing configurations makes these charts efficient reference tools. However, one must keep in mind that the free space information presented on these charts is generalized. Modifications to the bearing, such as the addition of shields or seals, may change the actual free space. In addition, due to differences in internal design configurations, information from one manufacturer's chart may not always be transferred to another manufacturer's product.

Rule of Thumb Equation

Probably the most complex method to determine a bearing's fill quantity is the Rule of Thumb equation. However, this method is just that, a 'rule of thumb,' and has limited accuracy. Keep in mind that some applications, such as those with available lubricant cavities or those operating with low speed factors, may not require an extremely accurate measurement of the bearing's free space. In these cases, the following equation should be sufficient.

$$\text{Free Space (cc's)} = \frac{w(D^2 - d^2) - 74251W_b}{1273.24}$$

w = bearing width (mm)

D = bearing OD (mm)

d = bearing ID (mm)

W_b = bearing weight (lbs.)



Run-In Procedures

Part 4

A proper run-in procedure is vital to the performance of the bearing and lubricant in applications where high speeds, fill quantities and certain pre-loads are critical. That's because during the run-in process, the initial grease fill is evenly distributed around the bearing elements. A grease collar is formed to optimize the release of the base oil in a way that the friction surfaces are wetted with just the right oil quantity. As a result, the rolling elements and the cage don't entrain the entire lubricating grease, but just the required amount of oil.

If the necessary run-in is omitted, excessive operating temperatures and/or an over-lubrication condition will result. It is best to consult with the lubricant manufacturer if you have any questions in this area or if your specific application does not reach a stable equilibrium operating temperature after it has been run-in.

A proper run-in procedure:

- Expels the excess grease found in the system
- Orients the lubricating film on each contact surface
- Creates a grease collar to deliver oil to the contact zone
- Establishes a low equilibrium operating temperature
- Achieves a sealed-for-life lubrication condition

Considerations for Run-In Procedures

Most lubricating greases can benefit from the displacement of excess grease, but not all lubricating greases will orient themselves on the bearing surface. There are several factors to consider:

- Certain soap-based greases are fibrous in texture and will set up an oriented matrix on the surface of the bearing raceway.
- A benefit to using a polyurea thickened grease is that it does not have this fibrous texture and the run-in procedure can either be reduced or eliminated.
- Follow recommended run-in procedures. Although there are alternatives for applications where speed or temperature cannot be varied or monitored, it is ideal to have some control of these parameters. Each bearing manufacturer has a specific run-in procedure that may differ from the examples below. Always check with your specific equipment/bearing OEM prior to performing a run-in.

Important Note:

To achieve the full benefits from these procedures, bearings should be run in the same direction in which they will operate. It is also advisable to perform the run-in at the actual application site, because the motion associated with shipping/handling and assembly of the bearings may affect the results of the controlled run-in.

Six Run-In Procedure Steps

1. Start at a reasonable low speed, typically 20% of the maximum operating speed. Closely monitor the temperature of the bearings.
2. Increase speed incrementally when a stable temperature is reached.
3. Continue the incremental increases in speed as described. If a rapid temperature increase occurs, stop the run-in process. This temperature spike indicates a pre-load due to thermal expansion. Maximum bearing temperatures should not exceed 70°C (158°F). Temperatures in excess of 70°C will cause excessive bearing pre-loads and possible permanent grease or bearing damage.
4. Allow the system to cool to room temperature.
5. Restart the procedure at the last speed prior to the temperature spike.
6. Continue reading the above cycle until an equilibrium temperature is reached at the maximum operating speed of the application. The ideal equilibrium operating temperature is approximately 35°C to 40°C (95°F to 105°F).

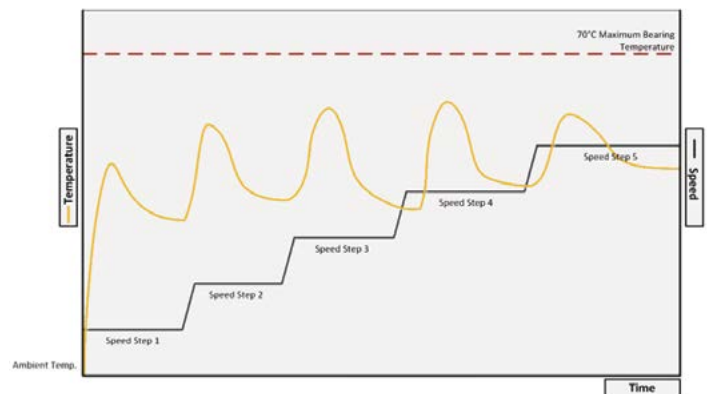

Variable-speed run-in procedure:

Increase speed incrementally when a stable temperature is reached

Alternative Run-In Procedure

When speed cannot be varied, run-in at constant speed is still possible. In this operation, the bearing should run at full speed for about 30 seconds. After stopping, the heat in the bearing dissipates. In this way, a dangerous temperature rise is prevented. The non-running time depends on the various design factors, but it should be at least five times greater than the running time. This interval should be repeated until the bearing temperature becomes constant.

Grease Filling a Bearing

Part 5

High-precision rolling bearings should always be lubricated with clean, fresh grease. It is also important that they be lubricated in a clean, dry environment so as to minimize the possibility of moisture or debris damaging the bearing.

Assuming that you have already determined the specific lubricant to be used, the first step is to determine the proper amount to be introduced into the bearing (refer to the section on [Proper Fill Quantity](#)).

The easiest way to measure grease quantity is to repack the grease into a graduated syringe. With this tool, the quantity can be monitored easily. Different size syringes with different tip configurations are commercially available. A fine tip on the syringe can increase the accuracy of where the grease is placed in the bearings as well.

A grease gun can be used for larger bearings where the fill quantity is large. However, if a grease gun is used, it must be calibrated first. The easiest way is to weigh the amount of grease that the gun puts out for each complete stroke. Because most grease guns do not expel consistent amounts per stroke, an average measurement should be used. For example pump out 10 strokes of grease and divide the total weight by 10 to determine the average quantity per individual stroke. Knowing the density of the grease, one can then convert the weight into volume.

$$\text{Volume (cm}^3\text{)} = \frac{\text{Weight (grams)}}{\text{Density (grams/cm}^3\text{)}}$$

Because most bearings are shipped with a corrosion protective coating, you must verify whether or not this coating has to be removed prior to lubrication. These coatings are typically miscible with mineral oil-based products and, therefore, are not required to be removed. However, it is imperative to remove these coatings when using silicone or perfluorinated-based products. In addition, high-speed and critical applications may also require the removal of these anti-corrosion coatings (refer to previous section on [Cleaning](#)).

If the bearing is already mounted in a housing (i.e., pillow block bearings), the grease should be introduced slowly into the grease fitting while rotating the bearing without load. If the bearing is in its free state, an equal amount of product should be introduced into the pockets between the rolling elements (Note: Divide the fill quantity by the number of rolling elements). The bearing should then be rotated without load so as to distribute the grease throughout the raceways. For precision bearings or pre-loaded bearings running in high speed applications, bearing run-in may be required (refer to previous section on [Run-In Procedures](#)).

Once a bearing has been lubricated, it should be put into service. If the lubricated bearing is to be stored, it should be wrapped in specially treated anti-corrosion paper (VCI paper) and placed in a clean, dry area.

How to Use a Grease Gun

Part 6



Grease guns can be filled manually or can be used in conjunction with a grease cartridge. Grease cartridges can allow for simple, clean relubrication with little waste. Grease cartridges typically contain 400 grams (14 ounces) of grease.

Operating Instructions

1. Pull out the grease gun piston until it is fully retracted. The automatic clamping device will lock into place.
2. Unscrew the top portion of the grease gun.
3. Remove the cap/foil cover from the grease cartridge.
4. Remove (cut with knife) or remove plastic cap of the opposite end of the cartridge.
5. Insert the cartridge into the grease gun.
6. Screw the top portion of the grease gun back on.
7. Depress the automatic clamping device and press the piston into the gun.

Push on the ventilation relief valve to allow for the escape of any entrapped air.

Sampling Procedure for Grease Analysis

Part 7

Monitoring grease condition is an important step in maintaining and tracking equipment reliability. It can detect lubricant break-down and aid in identifying potential problems before they occur. Corrective actions can be taken before other signs of deterioration begin to show, such as increases in operating temperatures, noise, and vibrations. By tracking the condition of grease in an application, it can provide important information on the quality of the grease, how it is performing and help adjust relubrication intervals.

The following is a general guideline to follow when removing samples from a piece of equipment or component to increase the accuracy of the analysis. Please contact your local Klüber Sales Engineer with any questions or concerns regarding this process.

Caution: Personal care must be taken when sampling from equipment. It is up to the user to determine the safest way to obtain a sample.

Sampling Containers

Ensure the material of the container will not interact with the material being sampled. Crushproof plastic or glass bottles are typically acceptable and preferred. Plastic bags can be used, but may interfere with analysis of grease consistency. Rags and other absorbent materials should be avoided. The size of the container should be selected to ensure sufficient sample quantity so that all of the intended analyses can be completed.

Cleanliness

To minimize potential contamination of a grease sample, the following precautions should be followed:

- Gloves should be worn for personal protection and to minimize sample contamination.
- Visually inspect and clean sampling containers and sampling equipment if needed.
- Clean the component to be sampled from dirt, dust and any other contaminants that may affect the results of the analysis.
- Once the sample is taken, the container should be capped or sealed to prevent leaking or further contamination.
- It is always good practice when shipping multiple samples to also seal each container in a separate airtight bag to prevent leakage and possible cross-contamination.

Sample Labeling

Proper labeling is of the utmost importance to ensure that the analysis is completed properly. Each component and piece of equipment should be given a unique identification for tracking and trending purposes. The samples should be taken one at a time and labeled immediately upon collection. As a minimum, the following information should be written on each sample bottle:

- Sample Date and Time – when the sample was physically taken from the component
- Equipment Description – brief summary of the facility and equipment, including the location, make, model, machine number, etc.
- Run time of the current grease
- Name of the baseline grease
- Contact information, including facility location and who took the sample

Sampling Procedure for Grease Analysis

Part 7

Procedure

Spatula Extraction

When the component is open and the grease is accessible, a spatula may be used to extract the sample.

1. If applicable, while the piece of equipment is still running, relubricate with the appropriate amount of fresh grease. Allow time for the freshly added grease to displace the used, in-service grease.
2. Shut down the piece of equipment and place it in a safe condition (i.e., lock out, tag out if necessary).
3. Use a spatula to clean the outermost layer of grease that has been contaminated by the environment. Discard this grease and thoroughly clean the spatula if it will be used again in the sampling process.
4. Using a clean spatula, take the sample of grease from the component. If removing from a bearing, the sample should be taken from the area closest to the rolling elements and cage. Open the sample bottle and scrape the grease into the bottle by using the side of the bottle, avoiding any outside contaminants from entering the bottle or coming into contact with the grease.
5. Seal the bottle and ensure that it is appropriately labeled as previously outlined. If available, place the sample bottle in its own Ziploc bag for shipping to prevent leakage or cross-contamination.

Vacuum Tube (Syringe) Extraction

When the grease in a component is inaccessible (sealed, within a housing, etc.), a syringe with a length of plastic tubing can be used to extract a sample from an inspection port, fill port or drain port.

1. Obtain a piece of plastic tubing that will assist in taking a grease sample from a point that is not reachable by means of a spatula. The minimum ID of the tube should be 1/8".
2. Cut a length of tubing that will allow easy access into the component. Ensure that the inside and outside of the tubing is clean and free of any dust, dirt or chemicals that could contaminate the grease sample. Be careful to avoid

contamination when cutting the tubing with tools and ensure that there are no burrs left on the cut end of the tube that could fall into the grease lubricated component or contaminate the grease sample.

3. Clean any dust, dirt or debris from the access point to prevent any foreign material from getting into the component.
4. Shut down the piece of equipment and place it in a safe condition (i.e., lock out, tag out if necessary).
5. Remove the access port, and insert the plastic tubing into the component far enough so that the tubing is extracting grease that is in direct contact with the component (i.e., between the rolling elements and cage of a bearing).
6. Draw the plunger on the syringe to extract the grease sample. Do not contaminate the syringe with grease; stop filling the length of tube with grease approximately two inches before the grease reaches the syringe.
7. Remove the tubing from the component and clean the outer surface of the tube. Open the respective clean sample bottle and inject the grease into the bottle. Try to avoid any outside contaminants from entering the bottle or coming into contact with the grease.
8. Steps 5 through 7 may have to be repeated several times to obtain an adequate amount of grease to be analyzed.
9. Seal the bottle and ensure that it is appropriately labeled as previously outlined. If available, place the sample bottle in its own Ziploc bag for shipping to prevent leakage or cross-contamination.

Once samples are properly contained and labelled, they should be adequately prepared for shipment to ensure that they arrive without damage. It is important to include the appropriate SDS with any grease shipment.

Grease Change-Over Procedure

Part 8

This procedure pertains to changing grease types or changing from one lubricant manufacturer to another. It explains how to relubricate bearings using a new grease and expel the previous grease.

Initial Requirements

(These conditions must be met.)

- A. Verify that the bearing arrangement allows excess lubricant to be bled from the system. Bearing damage may result in sealed-for-life systems or systems with oil tight sealing arrangements.
- B. Verify that the new lubricant and the previous lubricant are fully compatible. Mixing two incompatible products may result in chemical or physical changes which will lead to improper lubrication. Contact the lubricant manufacturers to verify compatibility.
- C. Verify that the subject bearing is operating properly prior to switching products. Improper fits, clearances, bearing configurations or existing bearing damage cannot be corrected by changes in lubrication.
- D. Verify that the bearing operating condition can accept a 100% fill condition. This procedure should not be applied to bearings which are designed to operate with limited grease quantities. Excessive bearing operating temperature may result in these cases.



Procedure

1. While the bearing is running, slowly pump in the new grease until the excess grease being bled from the bearing changes in consistency or color. This waste grease should eventually look similar to the new product.
2. Repeat step 1 after one to two hours of operation or after the bearing has reached a steady-state operating condition.
3. Run the bearing for one week (only if the previous relubrication frequency was greater than one week) and relubricate using the normal relubrication procedure.
4. Relubricate more frequently during the first two relubrication periods.
5. Initiate testing (power consumption, amperage draw, relubrication frequency, etc.)

Tips

- ✓ Always clean grease fittings before relubrication.
- ✓ Always pump slowly.
- ✓ Always apply new grease to a bearing that is turning.
- ✓ When in doubt ... contact Klüber Lubrication first!

Lubricant Storage and Shelf Life

Part 9

Lubricants should always be stored in their original container, in a clean, cool, dry location. Once the container has been opened, the lubricant is subject to contamination by moisture, dirt, and airborne particles. Lubricants should also always be kept in their original container and not transferred into other containers. This process only invites contamination. Note that most lubrication companies provide a wide variety of packaging sizes for this simple reason. It is recommended that the quantity of lubricant that is purchased be close to the amount of product necessary to do the particular lubrication job. In too many cases, excess lubricant is improperly stored. This situation may lead to the use of contaminated product, or product that has surpassed its recommended shelf life.



Shelf Life

The shelf life of a lubricating grease is that period over which a lubricant can be stored without experiencing a significant change in properties. Shelf life will differ from product to product depending on the product's formulation, NLGI grade (for greases) and storage condition. Bearings which are pre-lubricated also have a shelf life. Assuming that the bearing lubricant was applied close to its manufactured date, the bearing/lubricant combination will have the same shelf life as the lubricant. If a lubricated bearing (or a piece of lubricated equipment) is to be stored for a period that exceeds that of the grease shelf life, the bearing should be periodically operated without load. This will help to keep the lubricant homogeneous.

White Paper

Guide to Proper Bearing Lubrication Procedures

The *Guide to Proper Bearing Lubrication Procedures* has been prepared by Klüber Lubrication to serve as a general guide. If a more detailed explanation is required, please contact your nearest Klüber Lubrication representative or the manufacturer of the lubricant you are using.

Klüber Lubrication NA LP / 32 Industrial Drive / Londonderry, NH 03053 / Toll Free: 1-800-447-2238 / Phone: 603-647-4104 / Fax: 603-647-4106

Innovative tribological solutions are our passion. Through personal contact and consultation, we help our customers to be successful worldwide, in all industries and markets. With our ambitious technical concepts and experienced, competent staff we have been fulfilling increasingly demanding requirements by manufacturing efficient high-performance lubricants for more than 80 years.